

479 084 602  
K. C. ...



SOUTHERN CROSS GEARED SELF-OILING POWER PUMPS.

Page One.

# INSTALLATION — OPERATION

AND

# MAINTENANCE INSTRUCTIONS

FOR

*SOUTHERN CROSS*

**Figs. 2549 and 2550 Power Pumps**

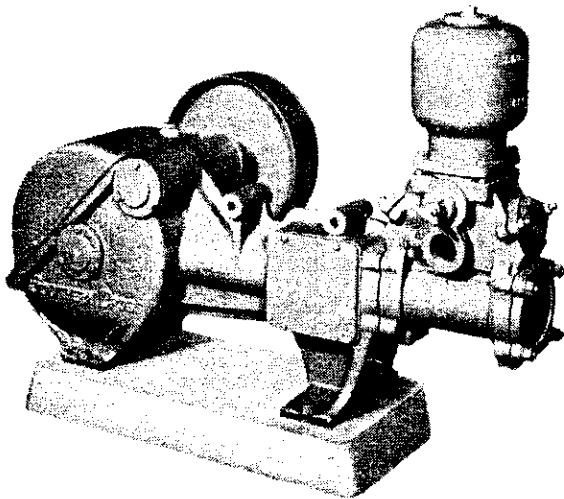

Fig. 2549.

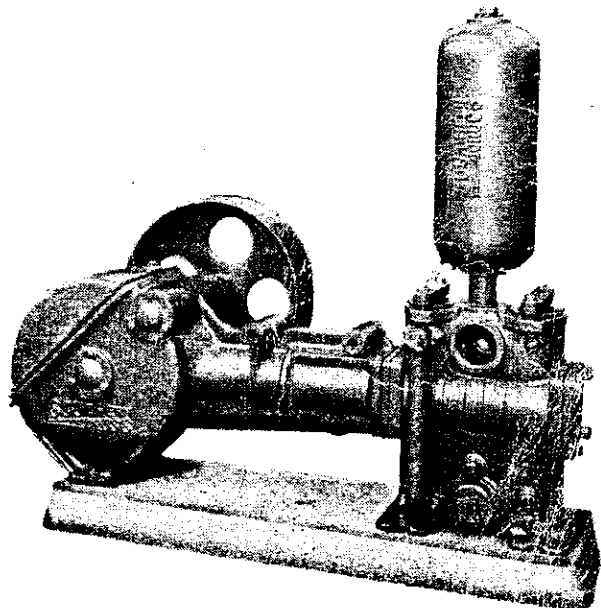

Fig. 2550

**Southern Cross Fig. 2549 Geared Self-Oiling Power Pump** incorporates the Mark AL-E Drive Gear, which has a 5in. stroke, combined with one of the following sizes of pumps:—Mark AN-E, 2½in. bore; Mark AN-F, 3in. bore; Mark AN-G, 3½in. bore; Mark AN-H, 4in. bore, and Mark AN-J, 5in. bore.

**Southern Cross Fig. 2550 Geared Self-Oiling Power Pump** incorporates the Mark AL-G Drive Gear, which has a 6in. stroke, combined with one of the following sizes of pumps:—Mark AN-I, 4in. bore; Mark AN-K, 5in. bore; and Mark AN-L, 6in. bore.

## INSTALLATION

### Assembling Pump

Some parts are removed from the pump for ease of packing and have to be fitted as follows:

**Fig. 2549:**

- (a) Remove air chamber from bottom of crate and air chamber rubber washer from hessian bag. Place washer in position and bolt air chamber to top of pump.
- (b) Fit washer to water cock valve assembly and screw into opening in side of pump.
- (c) Screw air valve into side of suction pipe boss.

**Fig. 2550:**

- (a) Take the short air chamber to pump connecting pipe and screw it into the top of the pump. Then screw on the air chamber.
- (b) Fit washer to water cock valve assembly and screw into opening at top of water by-pass connection.
- (c) Screw air valve assembly into hole near right hand foot on by-pass side of pump.

### Location

The pump should be located as near the source of supply as possible, but if sufficiently large suction piping is used the pump may be as much as 200 or 300 feet away. However, the suction lift from the surface of the water being pumped to the centre line of the pump must not be more than 18 feet, including friction. The pump should be placed so that it is accessible from all sides.

### Foundation.

The pump should be placed upon a level and firm foundation. A concrete block with the foundation bolts set into it, makes a suitable foundation. (Refer general arrangement illustrations on Page 3). A wooden template can be made to hold the bolts in position while the concrete is poured. The foundation bolts should be hung from the template so the tops will protrude 1½in. Fig. 2549, 2½in. Fig. 2550, from the concrete after the template is removed.

### Pipe Connections.

On 2½in. and 3in. Fig. 2549 Pumps, the suction is taken from the water by-pass side, and the discharge is taken from the opposite side. On 3½in., 4in. and 5in. Fig. 2549 Pumps, the discharge is taken from the opposite side to the water by-pass and the suction may be taken from either side.

On Fig. 2550 Pumps, the suction and discharge may be taken from either side of the pump, or the suction from one side and the discharge from the other.

### Piping.

Run all piping in as direct a line as possible; avoid all unnecessary turns; see that all joints and connections are tight, and if the pump lines are long, use a larger

size pipe than that for which the pump is screwed. This will reduce friction and so reduce the load on the pump.

Where a long pipe line is used for either the suction or discharge, fit a Union or Flanges in the line close to the pump for ease of uncoupling if the pump ever has to be moved.

### Suction Pipe.

The suction pipe should in no case be smaller than the size of the suction screwing of the pump, and if very long, it should always be larger. In laying the suction pipe a uniform grade should be maintained throughout to avoid air pockets, and if possible the pipes should have a drop of not less than 6in. in every 100 feet length towards the source of supply.

### Suction Chamber.

In installations where the suction lift exceeds 10 feet or the suction line is over 50 feet long, a suction chamber should be fitted to the suction line. The purpose of the suction chamber is to provide an even flow of water in the suction pipe. It also acts as a reservoir to quickly supply water to the pump at the start of each stroke and thus prevents "water hammer."

For 2½in. and 3in. Fig 2549 Pumps use a Mark BY-B Chamber and for all other pumps, use a Mark BY-C Chamber.

The suction chamber should be mounted in line with the flow of water in the suction pipe. To do this on 2½in. and 3in. pumps, screw a Nipple into the suction opening on the pump and then fit a Tee. Screw an M. and F. Bend into one side of the Tee and mount the suction chamber vertically from the Bend using a Nipple to make the connection. The suction pipe screws into the other side of the Tee. On the other sizes of pumps, screw the suction pipe into one side of the pump and mount the suction chamber vertically on a Nipple screwed into an M & F Bend which is screwed into the suction opening on the opposite side of the pump.

Periodically the top should be screwed off the suction chamber and water poured in until it is three-quarters full, leaving one-quarter of the chamber as an air-cushion. Periods between fillings will vary with different installations and experience will indicate how often it is necessary.

### Air Chamber.

An air chamber is fitted to the top of the pump to absorb pressure changes in the discharge line caused by variations in the flow, and also to help keep the water in the discharge line flowing smoothly.

The speed of a pump piston, during its travel in each direction, is not uniform, and on a pump not fitted with an air chamber the discharge flow would alter-



nately surge and slow down. This surging effect can cause a severe shock which could cause "water hammer." With an air chamber fitted to the pump these shocks are absorbed by a cushion of air.

The air in the air chamber is gradually absorbed by the water, and the chamber loses its effectiveness, so it is important that the air valve (on this page) be left slightly open to feed air into the air chamber.

### Foot Valve and Strainer.

A foot valve and strainer should always be fitted to the lower end of the suction pipe. The foot-valve keeps the suction pipe full of water when the pump is not being used, and ensures prompt starting on the next occasion. The strainer prevents foreign substances be-

ing drawn into the pump which could cause clogging of the pump valves.

### Check Valves.

A check valve should be fitted at or near the pump in the discharge pipe to relieve the pump valves of the back pressure of water in the discharge pipe.

Also it will enable work to be carried out on the pump without the water draining back out of the discharge pipe. **WARNING:** Under no circumstances fit a Gate or Globe Valve in the discharge pipe instead of a check valve, as the pump would be damaged if it was ever started with the Gate Valve or Globe Valve closed.

## RUNNING INSTRUCTIONS

### Priming.

For the initial run it may be necessary to prime the pump, but with a foot-valve fitted on the suction pipe it should not otherwise be required. If at any time the foot-valve should leak and make it necessary to prime the pump before starting, the foot-valve should be repaired immediately.

The fitting of a tee with a plug in the top in the suction line close to the pump provides a simple means of priming. The plug is simply removed and the suction line filled with water.

The pump can be primed by opening the pump by-pass, removing the plug from the top of the air chamber and pouring water into the top of the air chamber.

### Water By-Pass.

A Water By-pass is fitted to the pump so that the load on the driving machine can be reduced for starting. Each time before starting the pump, open the by-pass by

screwing the handle of the valve in an anti-clockwise direction. While this valve is open some of the water being pumped is by-passed from the discharge back into the suction. After the driving machine has got up speed, close the valve on the by-pass and the water will be passed through the discharge line.

### Air Valve.

Due to pressure in the discharge line, the air in the air chamber is gradually absorbed by the water and unless a small quantity of air is constantly fed into the chamber, it will fill with water and become useless. To make sure that there is always air in the air chamber, the air valve on the side of the pump should always be left slightly open so that on each suction stroke a small amount of air will be drawn into the pump with the water to feed the air cushion in the air chamber.

For most installations an opening of  $\frac{1}{4}$  to  $\frac{1}{2}$  of a turn on the valve is sufficient. On pumps operating with a high suction lift, an excessive opening of the valve will allow too much air into the pump and prevent it from operating.

## MAINTENANCE

### Gland.

After the pump has been in use for some time the gland on the plunger rod might leak and water will run from the drain hole at the pump end of the Drive Gear. To overcome this the Gearbox Pump End Cover Plate should be removed and the gland tightened. Do not tighten the gland too much, as this will produce unnecessary friction and wear, and will also increase the power necessary to operate the pump.

### Valves.

The Valves should be examined occasionally to see if they are seating properly. Foreign substances are likely to be drawn up through the suction pipe and become lodged between the valve and seat, causing leakage and a corresponding reduction in the capacity of the pump.

### Lubrication.

From the oil reservoir in the base of the gearbox, oil is carried by the main gearwheel to the highest point, and by a system of channels is distributed to all moving parts and then returned again to the reservoir.

For very hot climates, Southern Cross AL-E and AL-G Drive Gear Oil—S.A.E. 140 should be used in these

pumps, and for cooler climates, Southern Cross AL-E and AL-G Drive Gear Oil—S.A.E. 90 should be used. In some cases it may be found necessary to change oil for winter and summer use.

The Gearbox should be drained and refilled with fresh oil every 500 hours.

Fill the Gearbox up to the mark on the dipstick. When checking the oil level, clean the dipstick and screw it back in before taking a reading.

The approximate quantity of oil required to fill the gearbox to the mark on the dipstick is: Fig. 2549 Power Pump, 7 pints; Fig. 2550 Power Pump, 1 gallon 3 pints.

### To Replace Pump Buckets.

Remove the Gearbox Pump End Cover Plate. Loosen off setscrew in Crosshead and screw Plunger Rod out of Crosshead.

Loosen off the Splash Guard Setscrew and slip the Splash Guard off the Plunger Rod.

Remove the Inspection End Plate from the end of the Pump, loosen off the Packing Gland and the Plunger Rod, Plunger, Buckets, etc., can be removed.

Replace the Pump Buckets and reverse the above procedure to re-assemble Pump.



## To Fit New Valve Seats

If it is ever necessary to fit new valve seats to the pump, proceed as follows:

### Fig. 2549 Power Pump.

- (a) Remove the valve covers and gaskets and the air chamber and gasket.
- (b) Unscrew the valve studs and lift off the washers, springs and rubbers.
- (c) The valve seats can then be unscrewed using a pronged tool. The new valve seats can be screwed in with the same tool.

### Fig. 2550 Power Pump.

- (a) Undo the nuts holding the top and side clamps, remove the clamps, inspection port covers and gaskets.

- (b) Unscrew the valve guides and remove the springs, washers and rubbers.

- (c) It will be necessary to use a puller to remove the valve seats from the body.

To make a puller for the discharge seats, take a piece of 1/2 in. steel bar and screw a short 1/2 in. Whitworth thread on one end to screw into the valve seat. The other end should protrude above the top of the body and should have a long thread on it. A heavy piece of flat steel bar with a hole in the middle to take the 1/2 in. bar will also be required. Screw the bar into the valve seat, place the piece of flat steel in position across the body and then screw on a nut. The discharge valve seat will be withdrawn as the nut is tightened down.

A similar procedure is used for the suction valve seats but a longer piece of bar will be required.

To fit the new valve seats, place them in position and bump them in carefully with the squared end of a piece of timber.

# ELECTRIC MOTOR DRIVEN POWER PUMPING UNITS

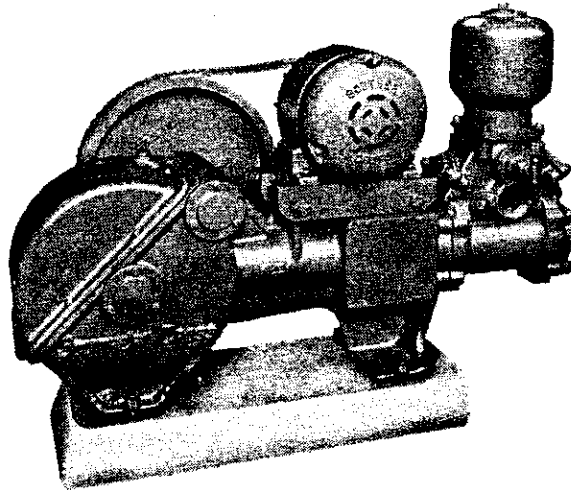

## Foundation

Make the foundation the same as for Figs. 2549 and 2550 Power Pumps (refer page 2).

## Fitting Electric Motor

The illustration above shows one method of mounting an electric motor. Note that for this electric motor the top flanges on the rails are set towards the pulley. For other Electric Motors it may be necessary to bolt the rails

on differently. The rails can also be bolted on with both top flanges in the opposite direction to that shown above; or with flanges towards each other; or with flanges set in opposite directions.

If the top flanges on the rails are not drilled to suit the electric motor, fit vee pulley on motor shaft, sit motor in position on rails, line up belt drive and then mark bolt hole positions on rail flanges. Drill flanges and then bolt on motor.

## Figs. 3064, 3141 and 3110 POWER PUMPING UNITS

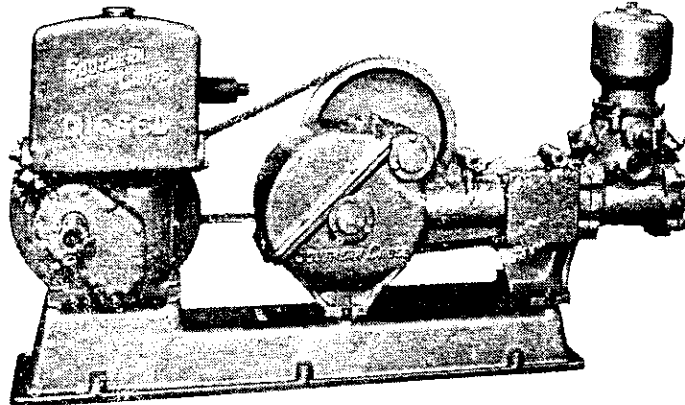

The Fig. 3064 Unit consists of a 2½ h.p. "ET" Diesel Engine driving a Fig. 2549 Power Pump. The Fig. 3141 Unit consists of a 3 h.p. "ET" Diesel Engine driving a Fig. 2549 Power Pump. The Fig. 3110 Unit consists of a 4 h.p. "ET" Diesel Engine driving a Fig. 2549 Power Pump. In each case the engine and pump are mounted on a Mark EM-G Cast Iron Base.

### To Make Concrete Block

- (1) After deciding where the unit is to be installed, sink a hole in the ground 1ft. to 1ft. 6in. deep and to the sizes shown on the "Bolt Template" illustration on Page 7.
- (2) Make a wooden template to hold the foundation bolts in their positions while the concrete is being poured.

- (3) Place template in position over the hole in the ground. Take six of the foundation bolts supplied with the engine and pump, put large washers on them and hang them from the template so the tops will project 3in. above the concrete when the template is removed.
- (4) Drive in small pegs around the ends of the cross-boards to hold the template in position. Check that the template is level and pack under the ends if necessary.
- (5) Mix a batch of concrete using 4 parts sharp stone, 2 parts sand and 1 part cement. See that the stone

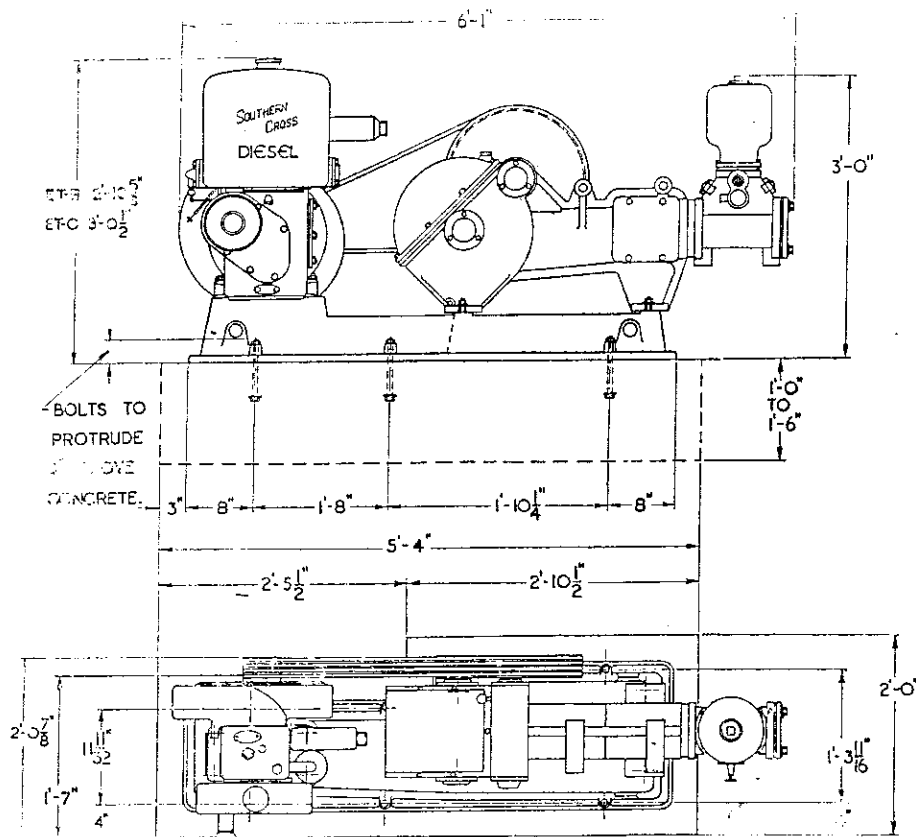

General Arrangement of Figs. 3064, 3141 and 3110 Power Pumping Units

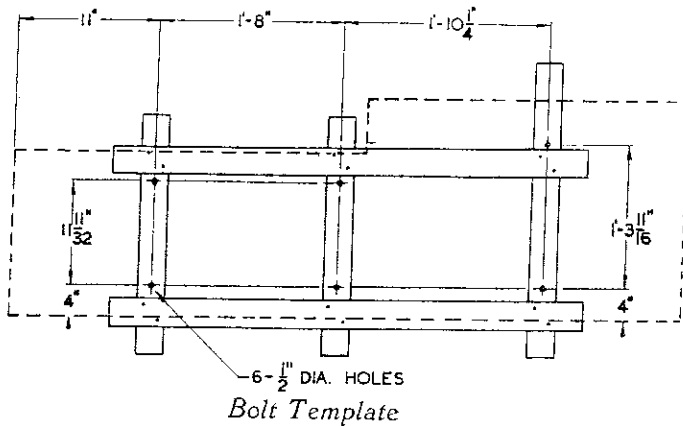

and sand are clean and do not contain any dirt. If they do, wash carefully before mixing. A block, 1ft. 6in. deep will require approximately 3 bags of cement, 1/3 yard of sand, and 1/3 yard of stone.

- (6) Fill the hole with concrete and at the same time place old bars and bolts in for reinforcements.
- (7) Allow the concrete to set for 2 or 3 hours and then carefully lift off the template, taking care not to disturb the bolts. If necessary, smooth off the top of the block with a mixture of 2 parts sand and 1 part cement. Allow the concrete to set for a day.

### Assembling Unit

- (1) Lift the base into position on the concrete block and with a spirit level, check that the base is level. Where necessary, place pieces of tin under the edge of the base to level it, and then tighten down the nuts on the foundation bolts, fitting spring washers under the nuts.
- (2) Take the studs supplied and screw them into the base, short threaded end first. To tighten the studs into the base, screw two nuts on each stud in turn, lock them together, tighten stud using spanner on the top nut, and then unlock nuts.
- (3) Unscrew the engine cylinder head cover nut, lift off cover and screw on lifting shackle. Lift engine on to base, remove shackle and replace cover and cover nut. Fit spring washers and nuts on holding down studs and tighten.
- (4) Screw pulley on to engine crankshaft and tighten, using the starting handle as a tommy bar.
- (5) Lift pump on to base, fit plain washers, spring washers and nuts on holding down studs and tighten.
- (6) See that the key is in position and then fit pulley on pump shaft, line up with engine pulley and tighten setscrew. Then fit belts. Each belt should have exactly the same number of links and should be tight.

**Note:** For further installation and operation instructions for the Power Pump, refer to earlier sections of this manual.

## Fig. 3126 POWER PUMPING UNIT

The Fig. 3126 Power Pumping Unit consists of a Mark GE-C Diesel Engine driving a Fig. 2550 Power Pump, mounted on a Mark CN-K Welded Steel Base.

### To Make Concrete Block

- (1) After deciding where the unit is to be installed, sink a hole in the ground 1ft. to 1ft 6in. deep and to the sizes shown on the illustration, "Positions of Foundation Bolt Holes" opposite.
- (2) Make a wooden mould 8in. high to suit a concrete block of the sizes shown. Nail wooden crosspieces across the top and bore 3/4in. holes in them at the positions shown.
- (3) Nail long pieces of timber along the sides of the mould to support it over the hole in the ground. Using a spirit level, check that the top of the mould is level.
- (4) Take the foundation bolts and hang them from the crosspieces so the tops will project 1 1/2in. above the concrete when the mould and crosspieces are removed.
- (5) Mix a batch of concrete using 4 parts sharp stone, 2 parts sand, and 1 part cement. See that the stone and sand are clean and do not contain any dirt. If they do, wash carefully before mixing. A block 1ft. 6in. deep will require approximately 12 bags of cement, 1 yard of sand and 1 1/3 yards of stone.

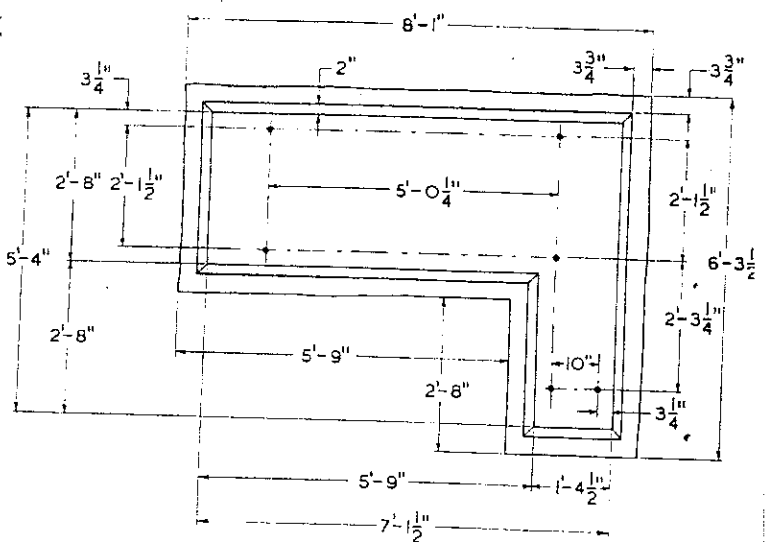

PLAN OF FOUNDATION BOLT LAYOUT

### Positions of Foundation Bolt Holes

- (6) Fill the hole to ground level and then place in some old bars or iron pipe to act as reinforcements. Then fill the mould to the top and smooth off the surface.
- (7) Allow the concrete to set for a day and then remove the crosspieces.

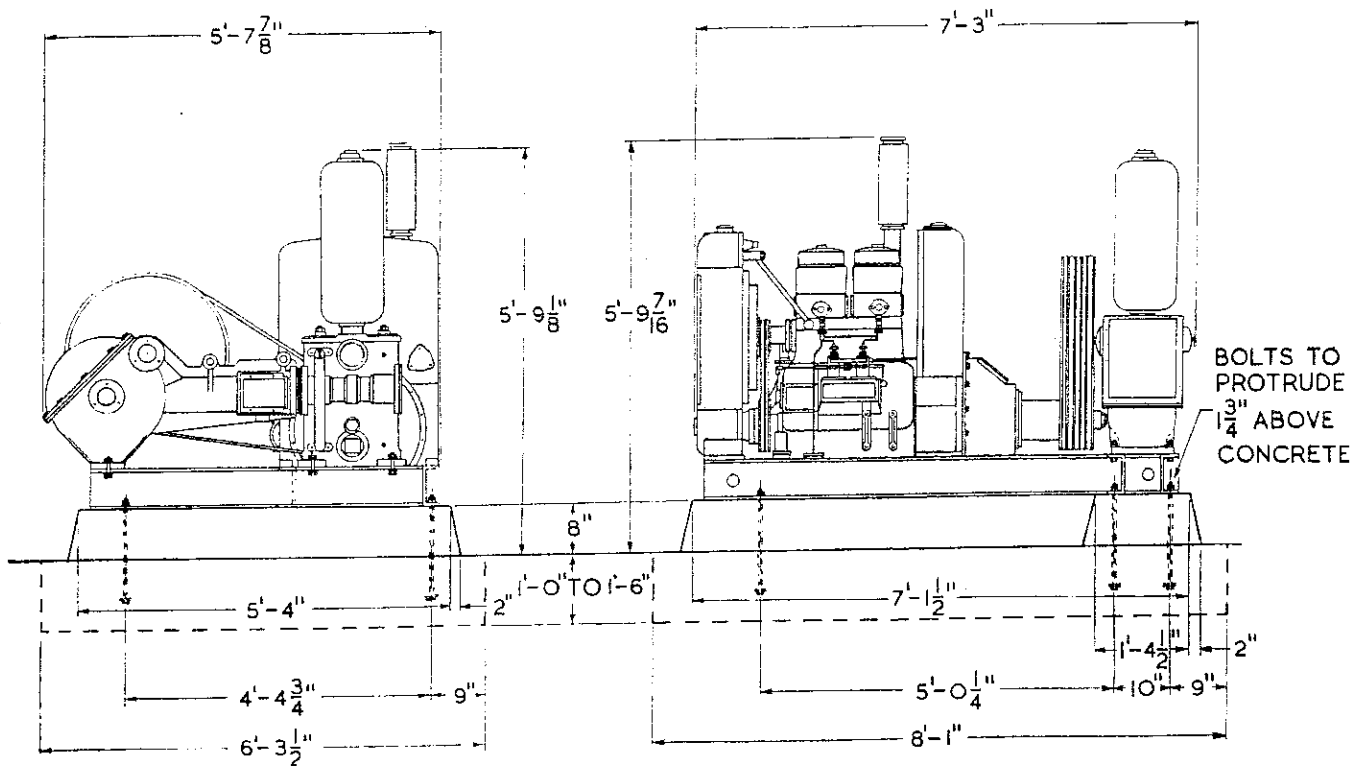

General Arrangement of Fig. 3126 Power Pumping Unit

### Assembling Unit

- (1) Lift the base into position on the concrete block and with a spirit level, check that the base is level. Where necessary, place pieces of tin under the edge of the base to level it and then tighten down the nuts on the foundation bolts, fitting spring washers under the nuts.
- (2) Assemble the belt drive on the engine as set out in the Engine Instruction Manual.
- (3) Screw the two 11in. by 5/8in. studs into the base at the flywheel housing position and screw the two 6in. by 5/8in. studs in the base at the front mounting bracket position. Then lift the engine on to the base. Lifting instructions are shown in the Engine Instruction Manual.

- (4) Remove the radiator bottom tank side plates and bolt radiator to base with four 1 3/8in. by 5/8in. setscrews. Fit spring washers on the other four engine to base studs and tighten nuts.
- (5) Lift the pump on to the base and bolt down using 3in. by 5/8in. bolts and fitting a plain and a spring washer under each of the nuts.
- (6) See that the key is in position in pump shaft and then fit pulley. Line up belt drive and tighten locking setscrew. Then fit belts. Each belt should have the same number of links and should be tight.

**Note:** For further installation and operation instructions for the Power Pump, refer to earlier sections of this manual.



Parts List for Mark AN-E, AN-F, AN-G, AN-H, AN-I, AN-J, AN-K, AN-L Power Pumps.

| 3/4 in. x 5 in. Mark AN-E | 3 in. x 5 in. Mark AN-F |         | 3/4 in. x 5 in. Mark AN-G |                                | 4 in. x 5 in. Mark AN-H |         | 5 in. x 5 in. Mark AN-J |         | 4 in. x 6 in. Mark AN-I |         | 5 in. x 6 in. Mark AN-K |         | 6 in. x 6 in. Mark AN-L |         | Name of Part               |
|---------------------------|-------------------------|---------|---------------------------|--------------------------------|-------------------------|---------|-------------------------|---------|-------------------------|---------|-------------------------|---------|-------------------------|---------|----------------------------|
|                           | Sym. No.                | No. off | Sym. No.                  | No. off                        | Sym. No.                | No. off | Sym. No.                | No. off | Sym. No.                | No. off | Sym. No.                | No. off | Sym. No.                | No. off |                            |
| AN-E1B                    | 1                       | AN-F1B  | 1                         | AN-G1B                         | 1                       | AN-H1B  | 1                       | AN-J1B  | 1                       | AN-I1   | 1                       | AN-K1C  | 1                       | AN-L1C  | Body                       |
| AN-E3                     | 2                       | AN-E3   | 2                         | AN-G3                          | 2                       | AN-G3   | 2                       | AN-G3   | 2                       | AN-I1   | 1                       | AN-K1C  | 1                       | AN-L1C  | Air Vessel Body.           |
| AN-E4                     | 1                       | AN-F4   | 1                         | AN-G4                          | 1                       | AN-H4   | 1                       | AN-J4   | 1                       | BY-D1B  | 1                       | BY-D1B  | 1                       | BY-D1B  | Suction Valve Cover.       |
| AN-E5                     | 2                       | AN-F5   | 2                         | AN-G5                          | 2                       | AN-H5B  | 2                       | AN-J5B  | 2                       | AN-K4   | 1                       | AN-K4   | 1                       | AN-K4   | Plunger                    |
| XA6                       | 4                       | XA6     | 4                         | XB6                            | 4                       | XB6     | 4                       | XB6     | 4                       | SE9     | 2                       | SE9     | 2                       | SE9     | Cylinder Head.             |
| XA7                       | 4                       | XA7     | 4                         | XB7                            | 4                       | XB7     | 4                       | XB7     | 4                       | SD10    | 1                       | SD10    | 1                       | SD10    | Cup Leather Ring.          |
| XA8B                      | 4                       | XA8B    | 4                         | XB8                            | 4                       | XB8     | 4                       | XB8     | 4                       | AN-K11  | 1                       | AN-K11  | 1                       | AN-K11  | Large Valve Spring Washer. |
| XA9B                      | 4                       | XA9B    | 4                         | XB9                            | 4                       | XB9     | 4                       | XB9     | 4                       | AN-K13  | 2                       | AN-K13  | 2                       | AN-K13  | Small Valve Spring Washer. |
| AN-G10                    | 1                       | AN-G10  | 1                         | AN-G10                         | 1                       | AN-G10  | 1                       | AN-G10  | 1                       | AN-I13  | 2                       | AN-K13  | 2                       | SD13    | Valve Seat.                |
| XA11                      | 4                       | XA11    | 4                         | XB11                           | 4                       | XB11    | 4                       | XB11    | 4                       | AN-I14  | 1                       | AN-K14  | 1                       | SD14    | Valve Stud.                |
| AN-E12                    | 1                       | XA12    | 1                         | AN-G12                         | 1                       | XB12    | 1                       | XC12    | 1                       | SD15    | 4                       | SD15    | 4                       | SD15    | Top Clamp.                 |
| XA13B                     | 4                       | XA13B   | 4                         | XB13                           | 4                       | XB13    | 4                       | XB13    | 4                       | AN-K17  | 1                       | AN-K17  | 1                       | AN-K17  | Packing Gland              |
| XA14                      | 2                       | XA14    | 2                         | XA14                           | 2                       | XA14    | 2                       | XA14    | 2                       | AN-K20  | 1                       | AN-K20  | 1                       | AN-K20  | Side Clamp.                |
| XA15                      | 2                       | XA15    | 2                         | XB15                           | 2                       | XB15    | 2                       | XB15    | 2                       | AN-I23  | 1                       | AN-K23  | 1                       | SD23B   | Valve Spring.              |
| XA16                      | 1                       | XA16    | 1                         | For AN-G, AN-H, AN-J use XA14. |                         |         |                         |         |                         | SD24    | 4                       | SD24    | 4                       | SD24    | Side Clamp Bolt.           |
| XA23                      | 1                       | XA23    | 1                         | XB23                           | 1                       | XB23    | 1                       | XB23    | 1                       | AN-I23  | 1                       | AN-K23  | 1                       | SD23B   | Barrel.                    |
|                           |                         |         |                           | XB23                           | 1                       | XB23    | 1                       | XB23    | 1                       | SD24    | 4                       | SD24    | 4                       | SD24    | Valve Seat.                |

Parts List for Mark AN-E, AN-F, AN-G, AN-H, AN-I, AN-J, AN-K, AN-L, AN-M, AN-N, AN-O, AN-P, AN-Q, AN-R, AN-S, AN-T, AN-U, AN-V, AN-W, AN-X, AN-Y, AN-Z

| 2in. x 5in.<br>Mark AN-E | 3in. x 5in.<br>Mark AN-F |          | 3 1/2in. x 5in.<br>Mark AN-G |          | 4in. x 5in.<br>Mark AN-H |          | 5in. x 5in.<br>Mark AN-J |          | 4in. x 6in.<br>Mark AN-I |          | 5in. x 6in.<br>Mark AN-K |          | 6in. x 6in.<br>Mark AN-L |        | Name of Part                     |
|--------------------------|--------------------------|----------|------------------------------|----------|--------------------------|----------|--------------------------|----------|--------------------------|----------|--------------------------|----------|--------------------------|--------|----------------------------------|
|                          | No. off                  | Sym. No. | No. off                      | Sym. No. | No. off                  | Sym. No. | No. off                  | Sym. No. | No. off                  | Sym. No. | No. off                  | Sym. No. | No.                      | Sym.   |                                  |
| AN-G25                   | 1                        | AN-G25   | 1                            | AN-G25   | 1                        | AN-G25   | 1                        | AN-G25   | 4                        | SD25     | 4                        | SD25     | 4                        | SD25   | Plunger Rod.                     |
|                          |                          |          |                              |          |                          |          |                          |          | 1                        | SD26     | 1                        | SD26     | 1                        | SD26   | Valve Guide.                     |
| AN-G29                   | 2                        | AN-G29   | 2                            | AN-G29   | 2                        | AN-G29   | 2                        | AN-G29   | 1                        | AN-K28   | 1                        | AN-K28   | 1                        | AN-K28 | Packing Gland.                   |
|                          |                          |          |                              |          |                          |          |                          |          | 1                        | AN-K29   | 1                        | AN-K29   | 1                        | AN-K29 | Plunger Nut                      |
| AN-G36                   | 1                        | AN-G36   | 1                            | AN-G36   | 1                        | AN-G36   | 1                        | AN-G36   | 4                        | SD30     | 4                        | SD30     | 4                        | SD30   | Plunger Rod Lock Nut.            |
|                          |                          |          |                              |          |                          |          |                          |          | 1                        | AN-K33   | 1                        | AN-K33   | 1                        | AN-K33 | Valve Washer.                    |
|                          |                          |          |                              |          |                          |          |                          |          | 3                        | SD43     | 3                        | SD43     | 3                        | SD43   | Plunger Rod.                     |
|                          |                          |          |                              |          |                          |          |                          |          | 4                        | SD44     | 4                        | SD44     | 4                        | SD44   | Cylinder Head.                   |
| AN-G49                   | 4                        | AN-G49   | 4                            | AN-G49   | 4                        | AN-G49   | 4                        | AN-G49   | 7                        | SD49     | 7                        | SD49     | 7                        | SD49   | Cylinder Head Gasket.            |
|                          |                          |          |                              |          |                          |          |                          |          | 4                        | SD50     | 4                        | SD50     | 4                        | SD50   | Inspection Port Cover Gasket.    |
| AN-E55                   | 2                        | AN-F55   | 2                            | AN-H55   | 2                        | AN-I55   | 2                        | AN-J55   | 4                        | SD52     | 4                        | SD52     | 4                        | SD52   | Packing Washer.                  |
| AN-G58                   | 1                        | AN-G58   | 1                            | AN-G58   | 1                        | AN-G58   | 1                        | AN-G58   | 4                        | SD54     | 4                        | SD54     | 4                        | SD54   | Valve Spring.                    |
|                          |                          |          |                              |          |                          |          |                          |          | 1                        | SD54     | 1                        | SD54     | 1                        | SD54   | Valve Rubber.                    |
| AN-E71                   | 1                        | AN-E71   | 1                            | AN-E71   | 1                        | AN-E71   | 1                        | AN-E71   | 2                        | AN-K55   | 2                        | AN-K55   | 2                        | AN-K55 | Spanner for Valve Guide.         |
| AN-E74                   | 1                        | AN-E74   | 1                            | AN-E74   | 1                        | AN-E74   | 1                        | AN-E74   | 1                        | AN-K70   | 1                        | AN-K70   | 1                        | AN-K70 | Pump Bucket.                     |
| AN-E75                   | 1                        | AN-E75   | 1                            | AN-E75   | 1                        | AN-E75   | 1                        | AN-E75   | 1                        | AN-E71   | 1                        | AN-E71   | 1                        | AN-E71 | Plain End Plate.                 |
| PC193                    | 1                        | PC193    | 1                            | PC193    | 1                        | PC193    | 1                        | PC193    | 1                        | AN-E74   | 1                        | AN-E74   | 1                        | AN-E74 | Water By-pass Connection.        |
|                          |                          |          |                              |          |                          |          |                          |          | 2                        | AN-E75   | 2                        | AN-E75   | 2                        | AN-E75 | Air Valve Screw.                 |
| YC220                    | 1                        | YC220    | 1                            | YC220    | 1                        | YC220    | 1                        | YC220    | 1                        | AN-E74   | 1                        | AN-E74   | 1                        | AN-E74 | Air Valve Assembly.              |
| YC221                    | 1                        | YC221    | 1                            | YC221    | 1                        | YC221    | 1                        | YC221    | 1                        | AN-E75   | 1                        | AN-E75   | 1                        | AN-E75 | Air Valve Housing.               |
| YC223B                   | 1                        | YC223B   | 1                            | YC223B   | 1                        | YC223B   | 1                        | YC223B   | 1                        | PC193    | 1                        | PC193    | 1                        | PC193  | Air Valve Spring.                |
| YC224                    | 1                        | YC224    | 1                            | YC224    | 1                        | YC224    | 1                        | YC224    | 2                        | YB203    | 2                        | YB203    | 2                        | YB203  | Water By-pass Connection Gasket. |
| YC225B                   | 1                        | YC225B   | 1                            | YC225B   | 1                        | YC225B   | 1                        | YC225B   | 1                        | YC220    | 1                        | YC220    | 1                        | YC220  | Water Cock Packing Gland.        |
| YC228                    | 1                        | YC228    | 1                            | YC228    | 1                        | YC228    | 1                        | YC228    | 1                        | YC221    | 1                        | YC221    | 1                        | YC221  | Water Cock Packing Nut.          |
|                          |                          |          |                              |          |                          |          |                          |          | 1                        | YC223B   | 1                        | YC223B   | 1                        | YC223B | Water Cock Valve Stem.           |
|                          |                          |          |                              |          |                          |          |                          |          | 1                        | YC224    | 1                        | YC224    | 1                        | YC224  | Water Cock Valve Stem Handle     |
|                          |                          |          |                              |          |                          |          |                          |          | 1                        | YC225B   | 1                        | YC225B   | 1                        | YC225B | Water Cock Valve.                |
|                          |                          |          |                              |          |                          |          |                          |          | 1                        | YC228    | 1                        | YC228    | 1                        | YC228  | Water Cock Gland Washer.         |
|                          |                          |          |                              |          |                          |          |                          |          | 1                        | YC246    | 1                        | YC246    | 1                        | YC246  | Air Vessel Drain Plug.           |
|                          |                          |          |                              |          |                          |          |                          |          | 1                        | YC247    | 1                        | YC247    | 1                        | YC247  | Air Vessel Drain Plug Washer.    |

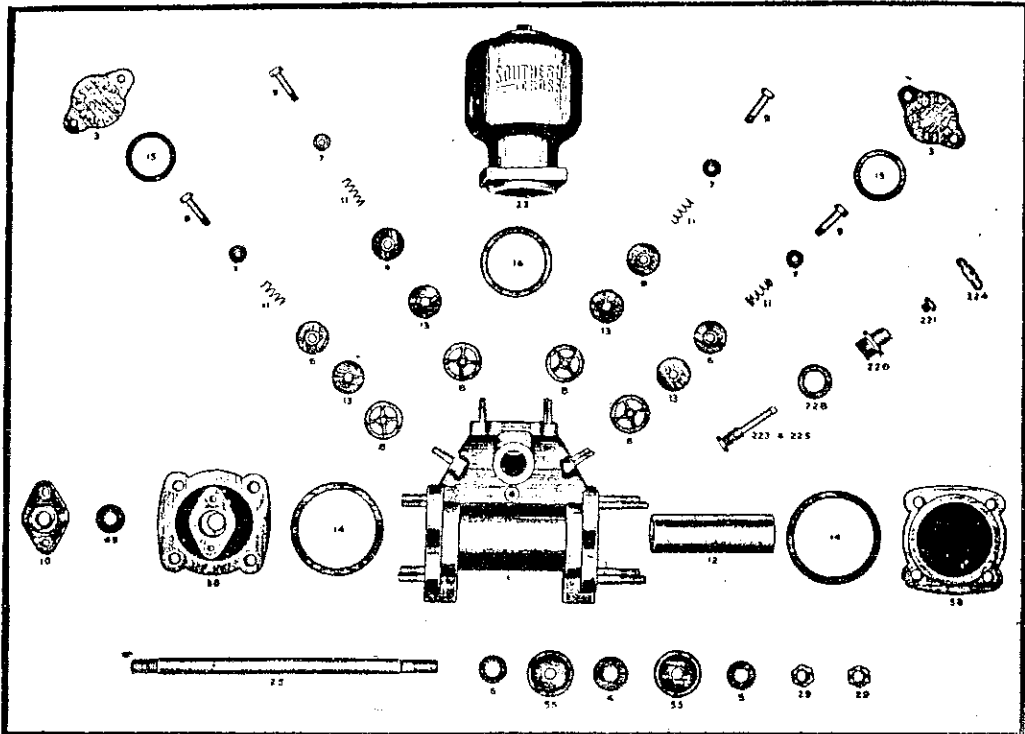

Marks AN-E, AN-F, AN-G, AN-H and AN-J Power Pump Parts

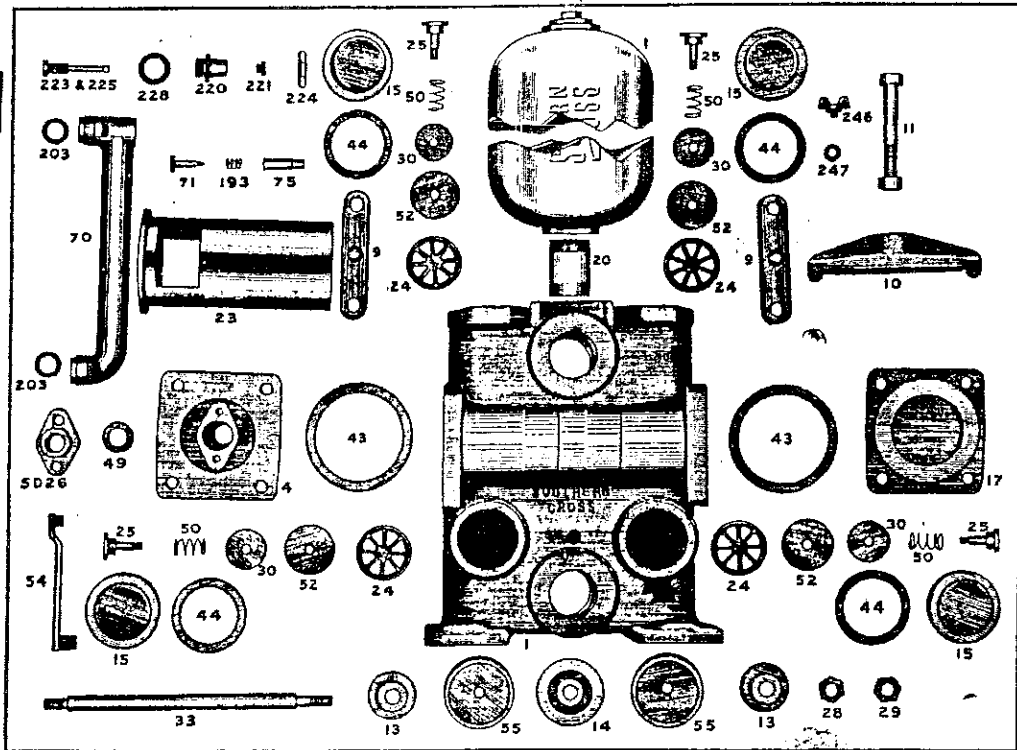

Marks AN-I, AN-K and AN-L Power Pump Parts

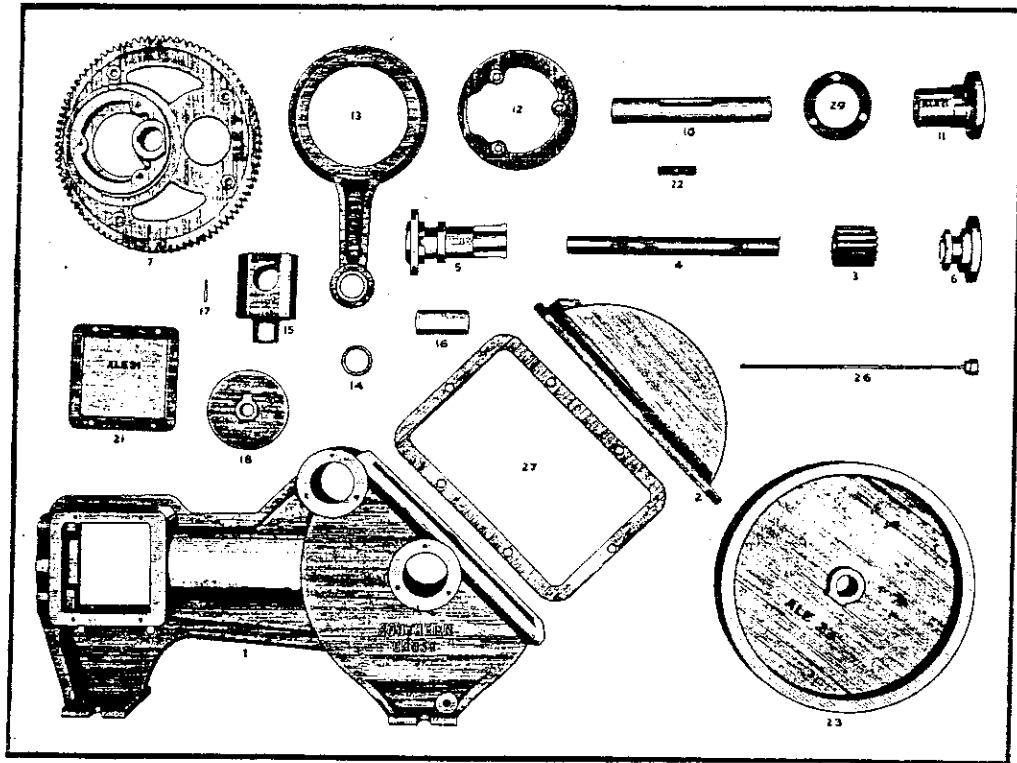

Marks AL-E and AL-G Drive Gear Parts.

**Parts List for Mark AL-E, AL-G Drive Gear.**

Mark AL-E Drive Gear fitted to Fig. 2549 Power Pumps—5in. stroke.  
 Mark AL-G Drive Gear fitted to Fig. 2550 Power Pumps—6in. stroke.

| Mark AL-E |          | Mark AL-G |          | Name of Part  |
|-----------|----------|-----------|----------|---|
| No. off   | Sym. No. | No. off   | Sym. No. |   |
| 1         | AL-E1C   | 1         | AL-G1C   | Gearbox.  |
| 1         | AL-E2    | 1         | AL-G2    | Gearbox Cover.  |
| 1         | AL-E3B   | 1         | AL-G3B   | Pinion.   |
| 1         | AL-E4B   | 1         | AL-G4B   | Pinion Shaft.   |
| 1         | AL-E5    | 1         | AL-G5B   | Pinion Shaft Long Bearing.  |
| 1         | AL-E6    | 1         | AL-G6B   | Pinion Shaft Short Bearing.   |
| 1         | AL-E7B   | 1         | AL-G7B   | Gearwheel.  |
| 1         | AL-E10   | 1         | AL-G10   | Gearwheel Shaft.  |
| 2         | AL-E11   | 2         | AL-G11   | Gearwheel Shaft Bearing.  |
| 1         | AL-E12   | 1         | AL-G12   | Eccentric Cover Plate.  |
| 1         | AL-E13   | 1         | AL-G13   | Connecting Rod.   |
| 1         | AL-E14   | 1         | AL-G14   | Connecting Rod Small End Bush.  |
| 1         | AL-E15   | 1         | AL-G15   | Crosshead.  |
| 1         | AL-E16   | 1         | AL-G16   | Crosshead Pin.  |
| 1         | AL-G17   | 1         | AL-G17   | Crosshead Pin Locking Screw.  |
| 1         | AL-E18   | 1         | AL-G18   | Splash Guard.   |
| 2         | AL-E21   | 2         | AL-G21   | Gearbox Pump End Cover Plate.   |
| 1         | AL-E22   |           |          | Gearwheel Key.  |
| 1         | AL-E23B  |           |          | Vee Pulley: AL-E23B 21½in. P.C.D. x 4 A Grooves.                                      |
| 1         | AL-E26   | 1         | AL-G26   | Dipstick Assembly.  |
| 1         | AL-E27   | 1         | AL-G27   | Gearbox Gasket.   |
| 4         | AL-E29   | 4         | AL-G29   | Gearbox Bearing Gasket.   |
| 1         | AL-E31B  | 1         | AL-G31   | Flat Pulley: AL-E31B 21½in. Dia. x 4in. Face; AL-G31, 23in. Dia. x 6in. Face.         |
| 1         | AL-E33   | 1         | AL-G33   | Vee Pulley: AL-E33, 21½in. P.C.D. x 6 B Grooves; AL-G33, 21½in. P.C.D. x 6 B Grooves. |
|           |          | 1         | AL-G36   | Vee Pulley, 28½in. P.C.D. x 5 C Grooves.  |
| 2         | AL-E38   | 2         | AL-G38   | Electric Motor Base Rails.  |